

Burford® Orbital Pan Shaker

MODEL 578-RIGHT HAND, MODEL 579-LEFT HAND

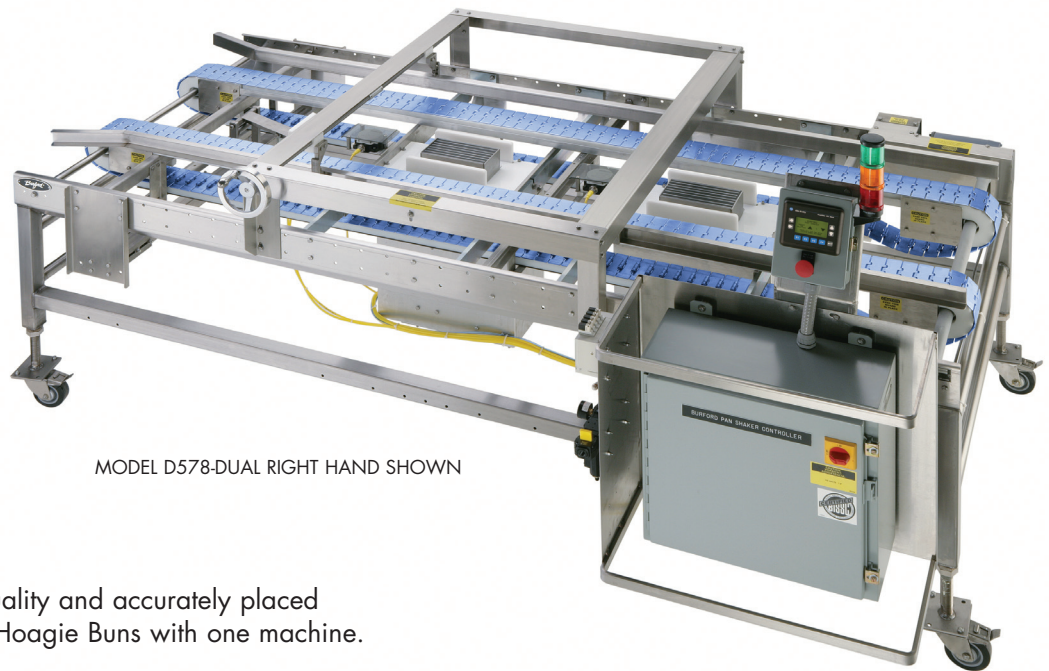

MODEL D578-DUAL RIGHT HAND SHOWN

Achieve consistent, high quality and accurately placed Hamburger, Hot Dog and Hoagie Buns with one machine.

Positive Dough correction is obtained easily with the adjustable 578 controller.

- Simple positive adjustment
- Labor savings
- Optional conveyor with self centering pan guides
- Positive dough placement
- User friendly controls: shake speed, pan position, number of shakes, dough position
- Easy pan type setup for all controls
- PLC controlled
- AC drive
- Quick connect setup

The Solution!

Improves dough yield with the ***circular motion*** of the Burford Orbital Pan Shaker

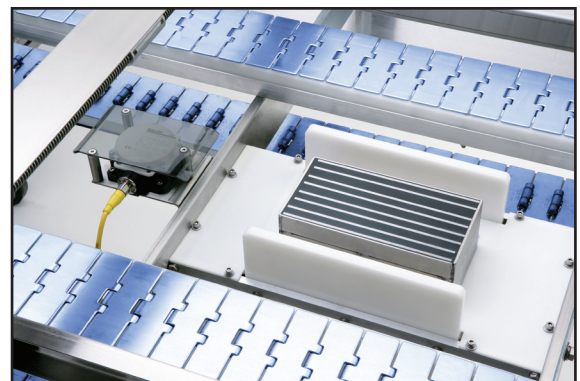

PRACTICAL SOLUTIONS THROUGH INNOVATIVE TECHNOLOGIES

Burford®
(bc)

CALL US TODAY 1-877-BURFORD (287-3673)

P.O. Box 748 • Maysville, OK 73057 • 1-405-867-4467 • Fax 1-405-867-4219 • e-mail: sales@burford.com • website: www.burford.com

Copyright © Burford Corp. All rights reserved. Burford Corp is a registered trademark with the US Patent & Trademarks office.

ORBITAL PAN SHAKER WITH STAND

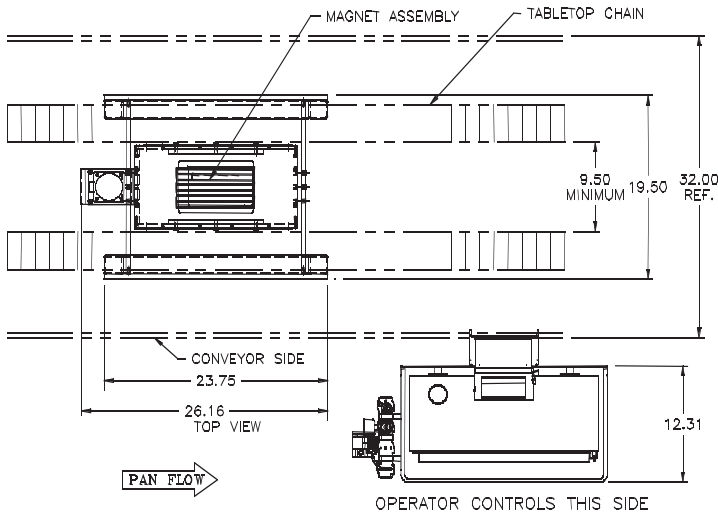

Features

- Dual shaker up to 34 pans per minute*
- Single shaker up to 25 pans per minute*
- Simple menu based adjustment
- Variable speed motor drive
- Integrates existing conveyor

Options

- High speed dual shaker
- Special conveyors
- Alternate electrical specification

* Depending on pan spacing and pan size

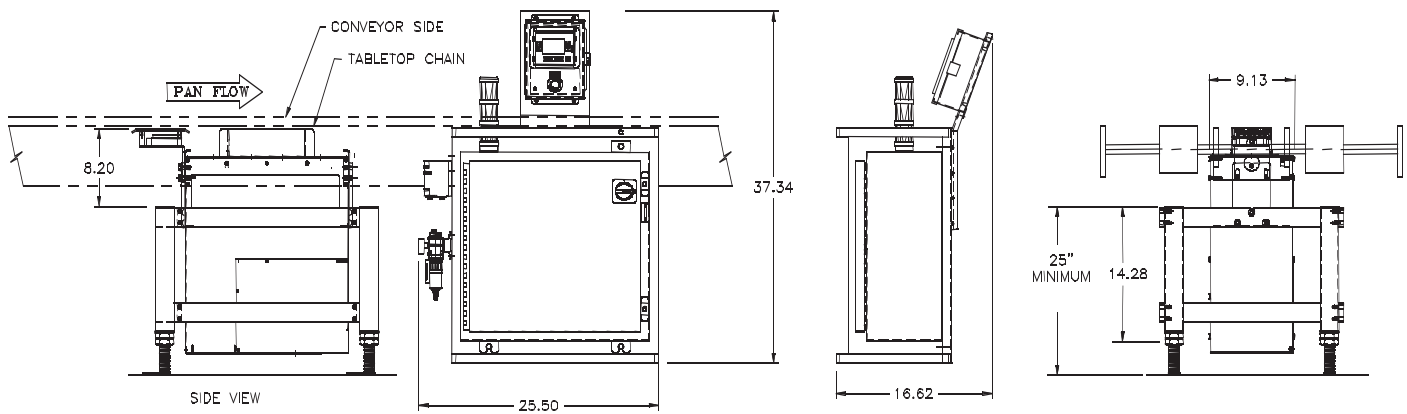

SPECIFICATIONS

ELECTRICAL:

115 VOLT, 60HZ, 1 PHASE (STD)

9 AMPS

DRIVE MOTOR:

1/4 HP A.C. VAR SPEED

AIR REQUIREMENTS:

60 PSI MINIMUM, 80 PSI MAXIMUM

@.436 CU. FT. FREE AIR PER MIN.